

HARDWARE
FOR GLASS

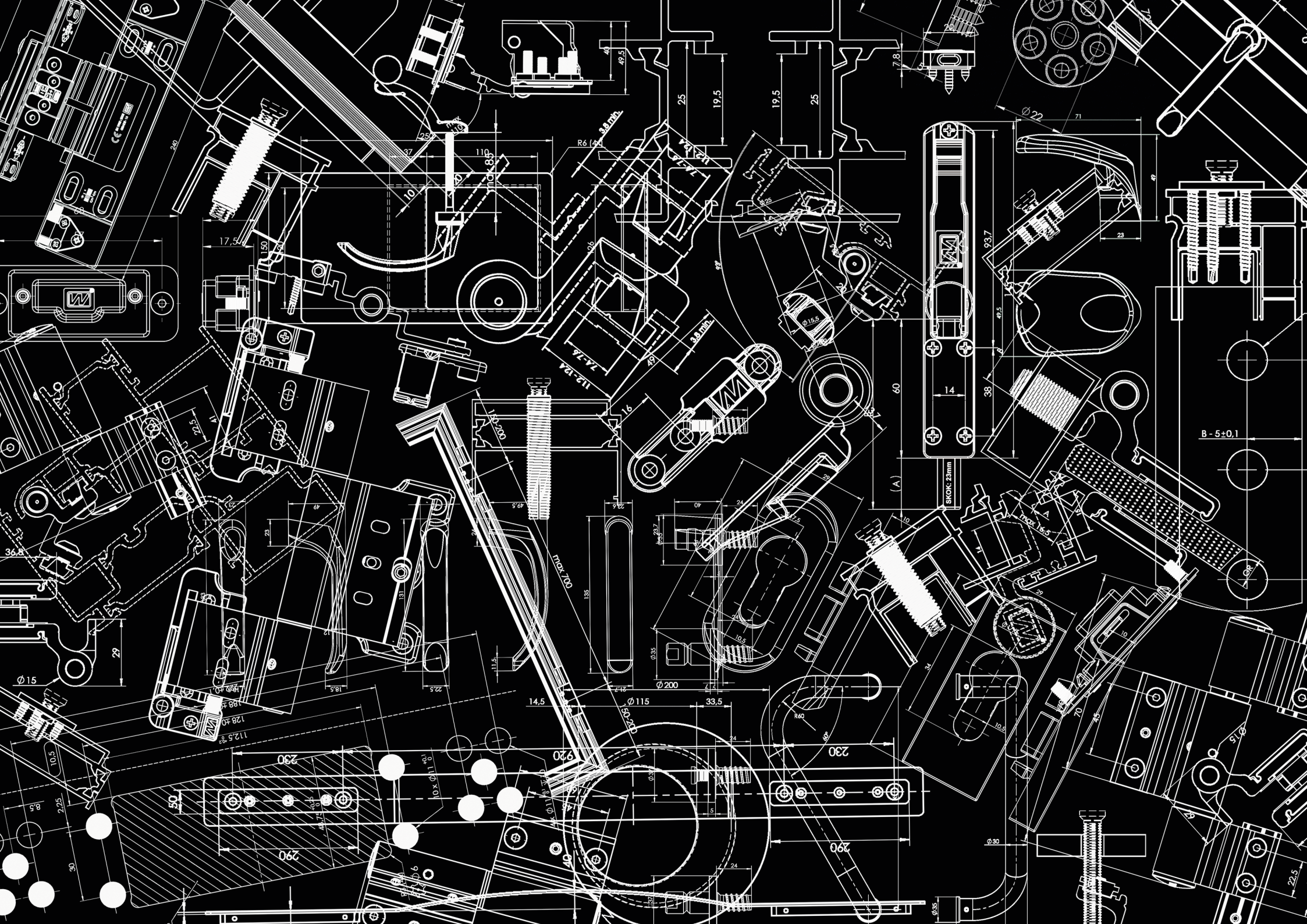







WTA / WTB

HINGES / GLASS SHEET

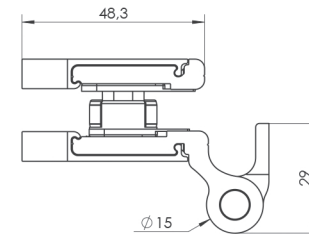
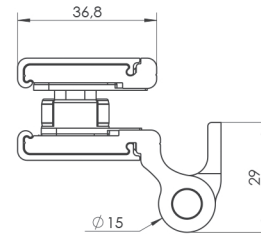
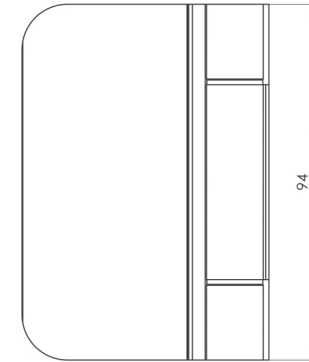
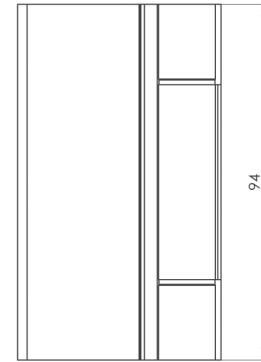

WT HINGE ADJUSTMENT





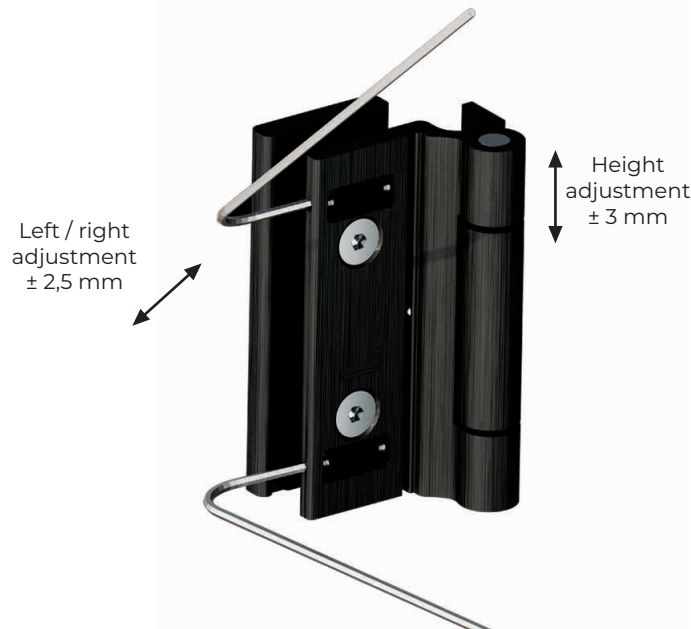



- 
7016
- 
7021
- 
7024
- 
9005
- 
8077
- 
8019
- 
8017
- 
8003
- 
9001
- 
1036W
- 
9010
- 
9016
- 
7035
- 
9006
- 
SILVER
- 
ANODA NATURALNA
- 
INOX COATING
- 
GOLD W3
- 
GOLD W4
- 
RAL
- 
C-35 ANODA CZARNA F40



WTA AND WTB HINGE CLASSIFICATION EN 1935:2002 + EN 1935:2002/AC:2003

for use in emergency exit doors

							
4/4	7/7	5/7	0/1	1/1	4/4	0/1	12/14





TOOLING IN FRAME PROFILE



WT 80104710

WT 80104990

RIVET NUTS FIXING SET
SCREW DOWELS FIXING SET

ALUMINIUM OR STEEL PROFILES WITH ONE PARTITION
ALUMINIUM PROFILES WITH MIN. 2 PARTITIONS, FILLED DOOR FRAME

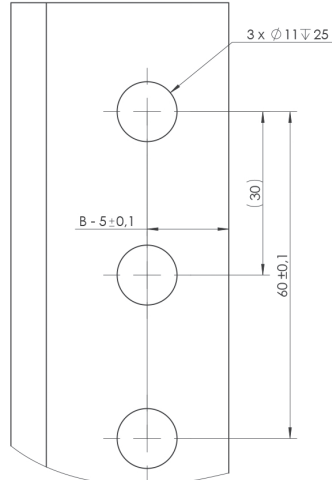
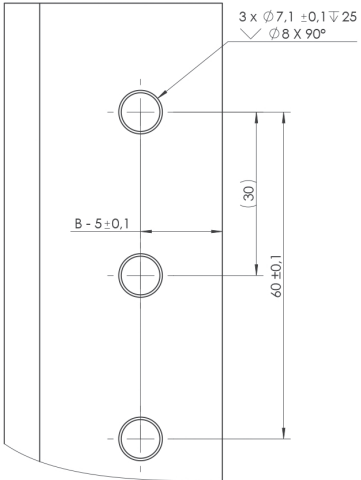

TOOLING IN GLASS SHEET

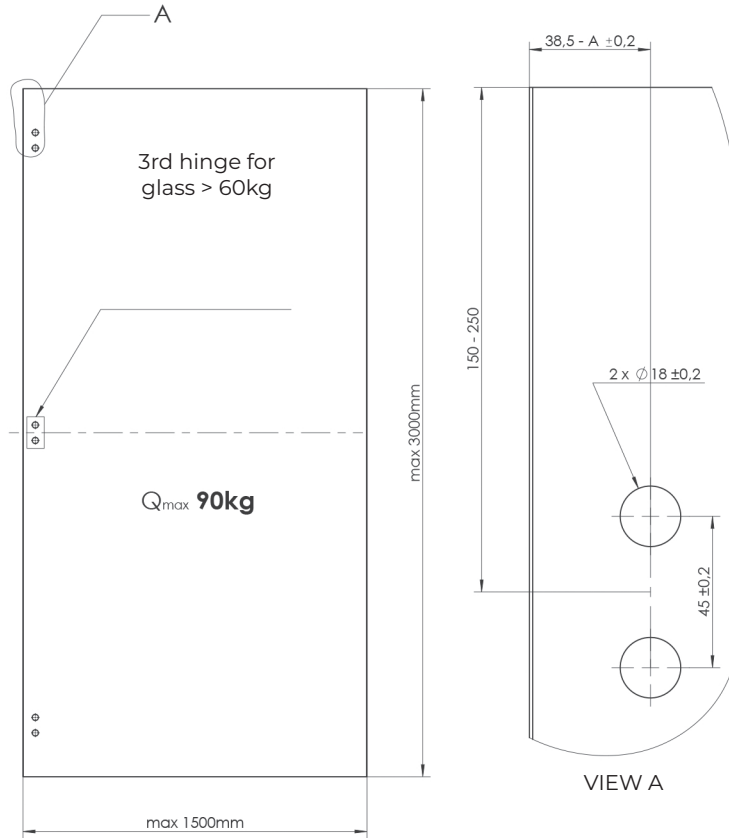

GAP A [mm]	DIMENSION IN GLASS D [mm]
4	34,5 ± 0,2
4,5	34,0 ± 0,2
5	33,5 ± 0,2
5,5	33,0 ± 0,2
6	32,5 ± 0,2
6,5	32,0 ± 0,2
7	31,5 ± 0,2
7,5	31,0 ± 0,2
8	30,5 ± 0,2

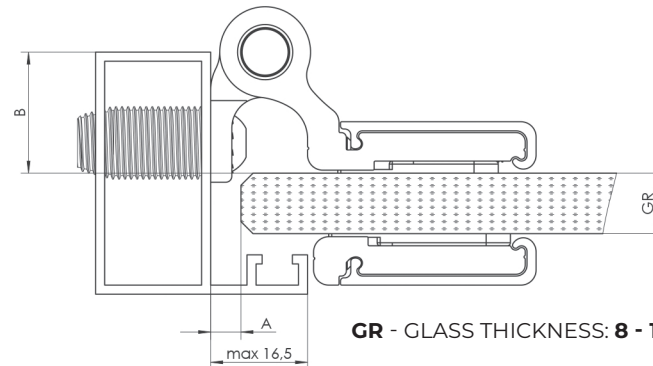

GR - GLASS THICKNESS: 8 - 12MM





MAGNETIC DOOR HANDLE

MAGNETIC / GLASS SHEET

MAGNETIC DOOR HANDLE SM10M1
GLASS SHEET - FRAME PROFILE

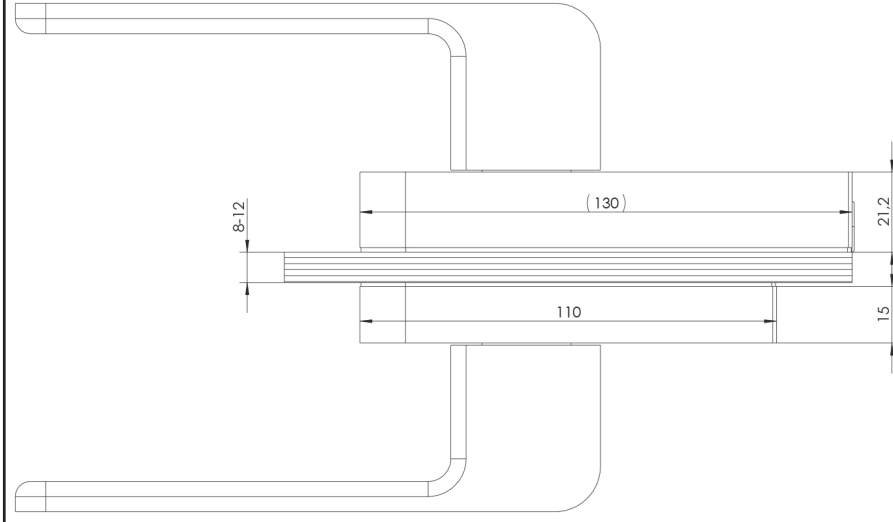

MAGNETIC DOOR HANDLE SM10M2
GLASS SHEET - GLASS SHEET

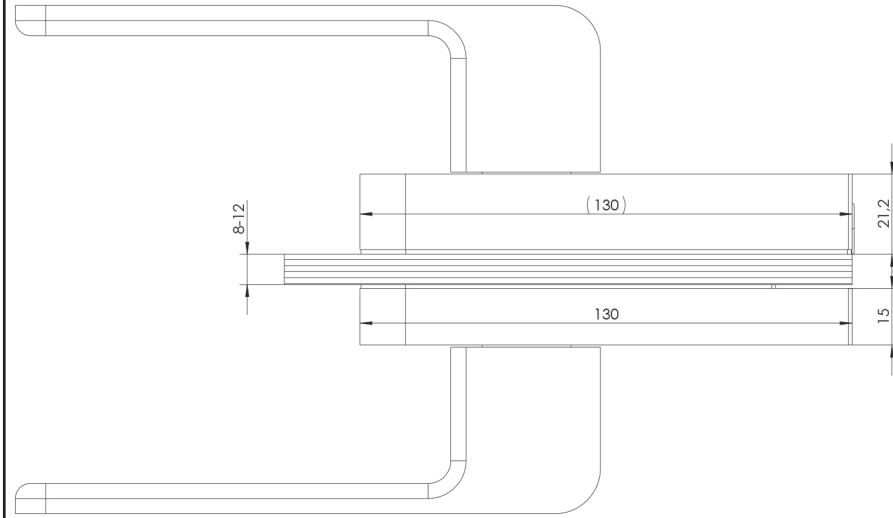

- 
7016
- 
7021
- 
7024
- 
9005
- 
8077
- 
8019
- 
8017
- 
8003
- 
9001
- 
1036W
- 
9010
- 
9016
- 
7035
- 
9006
- 
SILVER
- 
ANODE NATURAL
- 
INOX COATING
- 
GOLD W3
- 
GOLD W4
- 
RAL
- 
C-35 ANODE
BLACK F40





DIMENSIONS

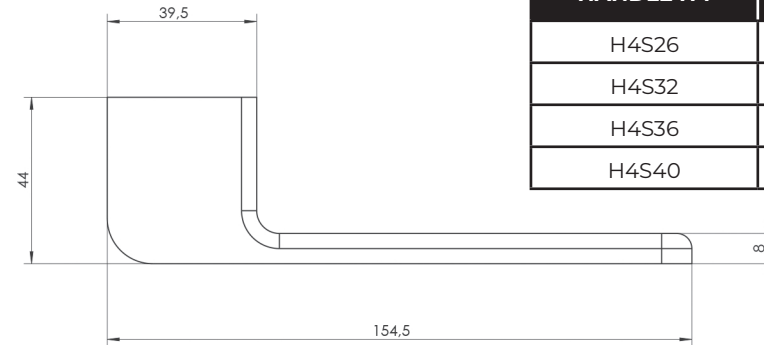
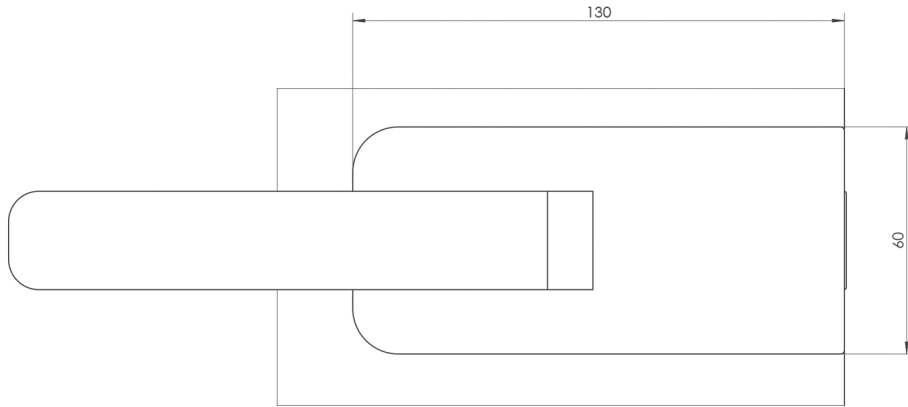

HANDLE H4	S [mm]
H4S26	26
H4S32	32
H4S36	36
H4S40	40

TOOLING IN GLASS SHEET

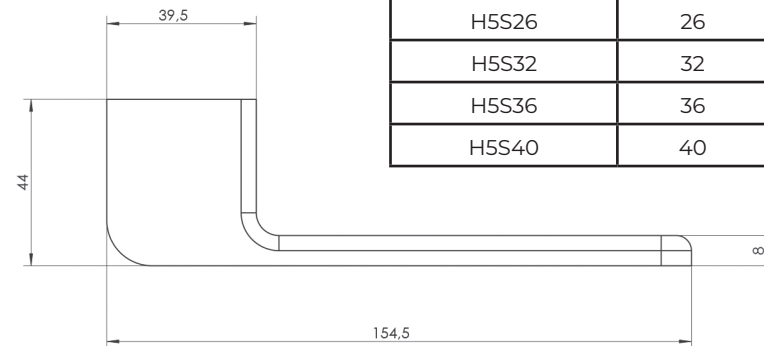
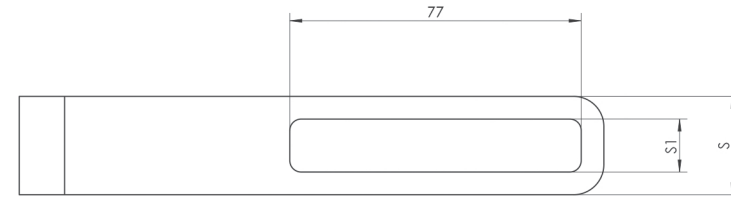
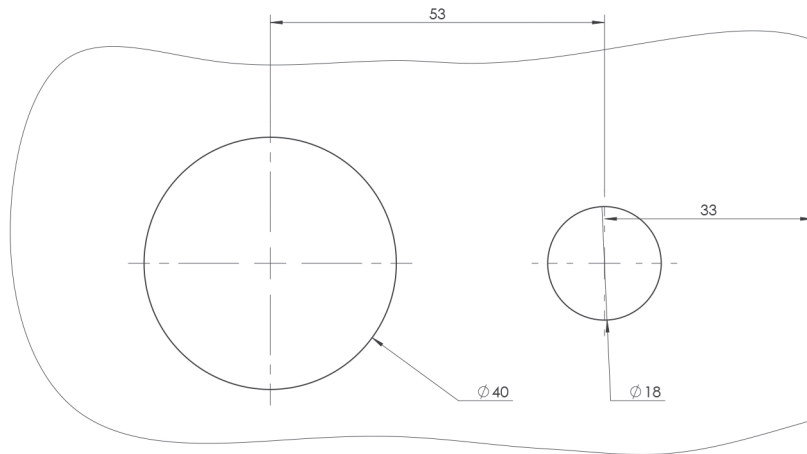

HANDLE H5	S [mm]	S1 [mm]
H5S26	26	14
H5S32	32	20
H5S36	36	24
H5S40	40	28





HANDLE WITH WC LOCK

MAGNETIC / GLASS SHEET

MAGNETIC DOOR HANDLE SM10M1
GLASS SHEET - FRAME PROFILE

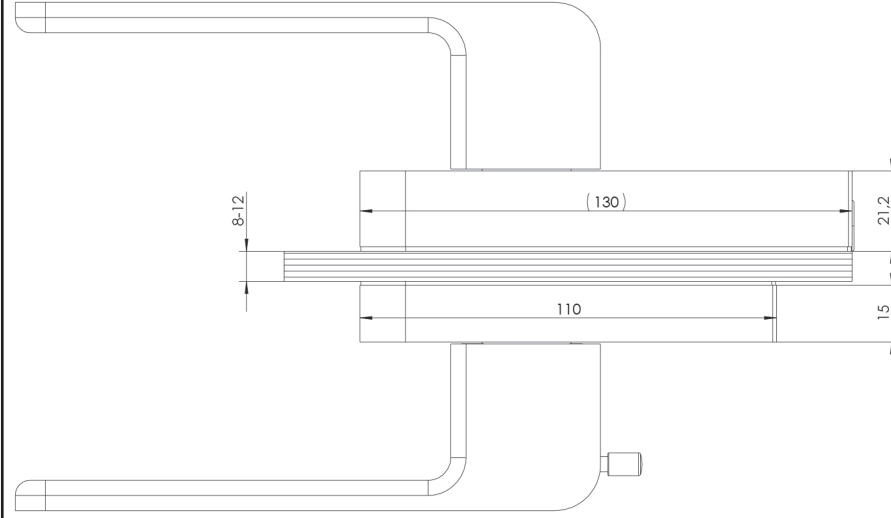

MAGNETIC DOOR HANDLE SM10M2
GLASS SHEET - GLASS SHEET

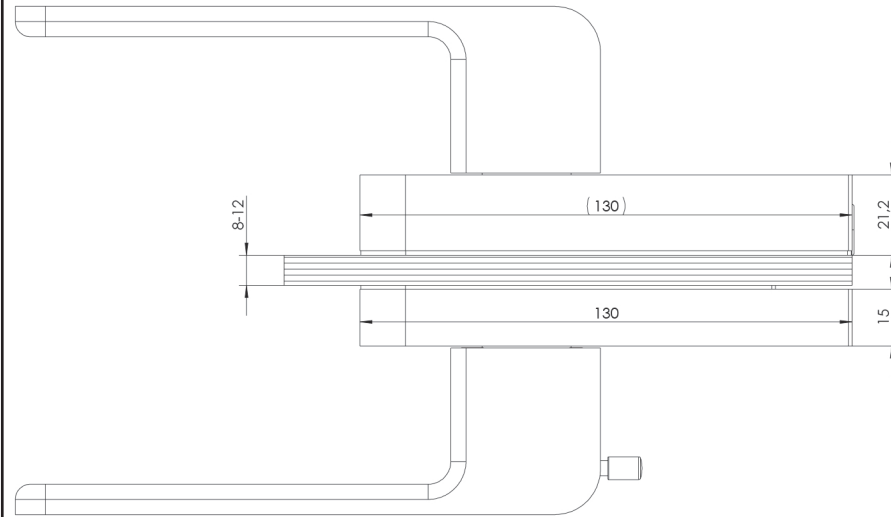

- 
7016
- 
7021
- 
7024
- 
9005
- 
8077
- 
8019
- 
8017
- 
8003
- 
9001
- 
1036W
- 
9010
- 
9016
- 
7035
- 
9006
- 
SILVER
- 
ANODE NATURAL
- 
INOX COATING
- 
GOLD W3
- 
GOLD W4
- 
RAL
- 
C-35 ANODE
BLACK F40
- 
C-35 ANODE
BLACK F40





-  7016
-  7021
-  7024
-  9005
-  8077
-  8019
-  8017
-  8003
-  9001
-  1036W
-  9010
-  9016
-  7035
-  9006
-  SILVER
-  ANODE NATURAL
-  INOX COATING
-  GOLD W3
-  GOLD W4
-  RAL
-  C-35 ANODE BLACK F40

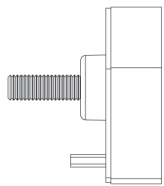
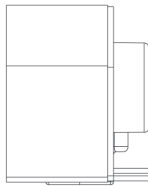
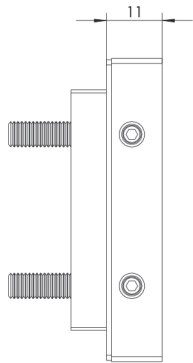
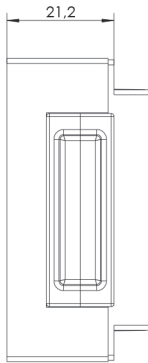
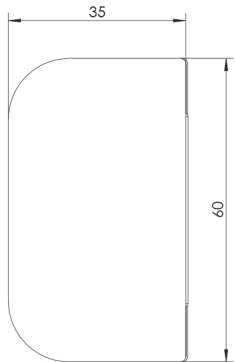

PROCESSING FOR DOOR FRAME LATCH

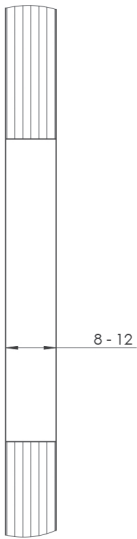
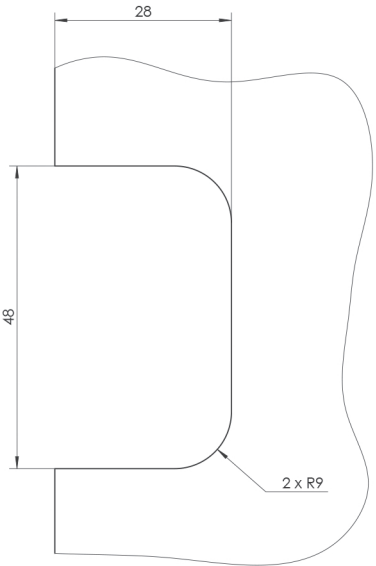



TAF 2 (GLASS-GLASS SHEET)

DOOR FRAME LATCH / GLASS SHEET

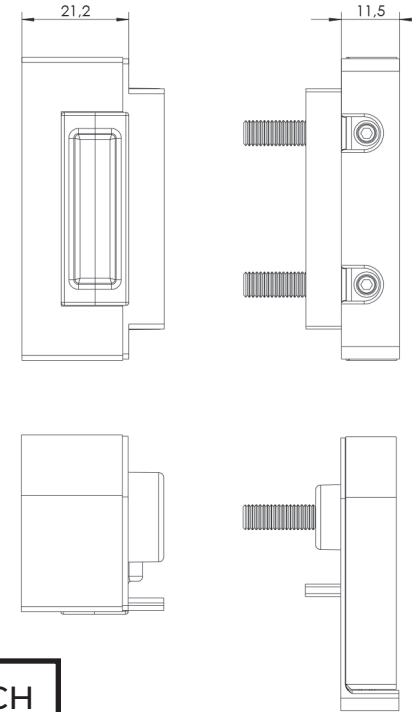
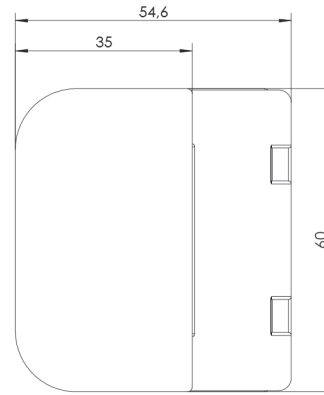

PROCESSING FOR DOOR FRAME LATCH

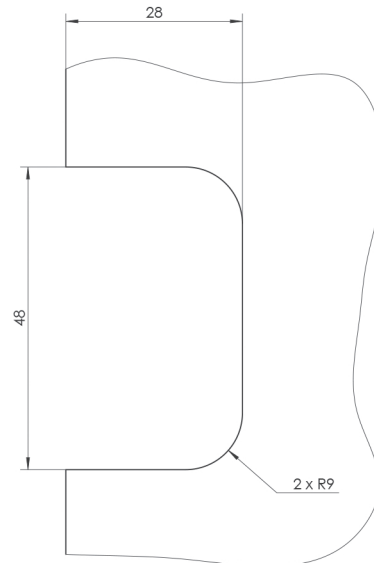

- | | | | |
|--|--------------|--|----------------------|
| | 7016 | | 7021 |
| | 7024 | | 9005 |
| | 8077 | | 8019 |
| | 8017 | | 8003 |
| | 9001 | | 1036W |
| | 9010 | | 9016 |
| | 7035 | | 9006 |
| | SILVER | | ANODE NATURAL |
| | INOX COATING | | GOLD W3 |
| | GOLD W4 | | RAL |
| | | | C-35 ANODE BLACK F40 |





ALU1

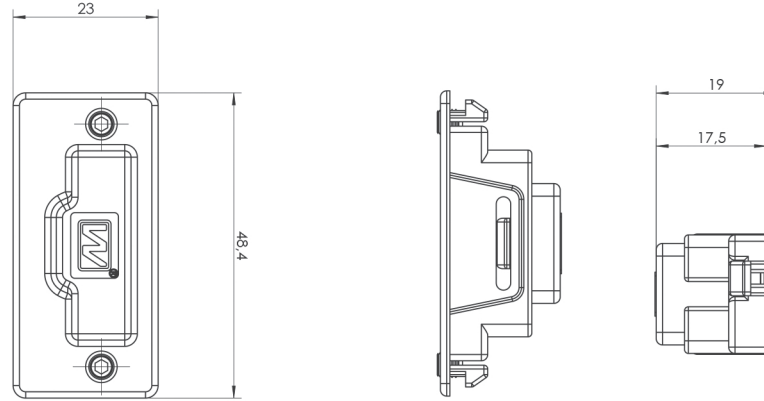

QUICK AND EASY INSTALLATION IN THE FRAME PROFILE WITH A WALL THICKNESS BETWEEN **1,2 AND 2,5MM**.

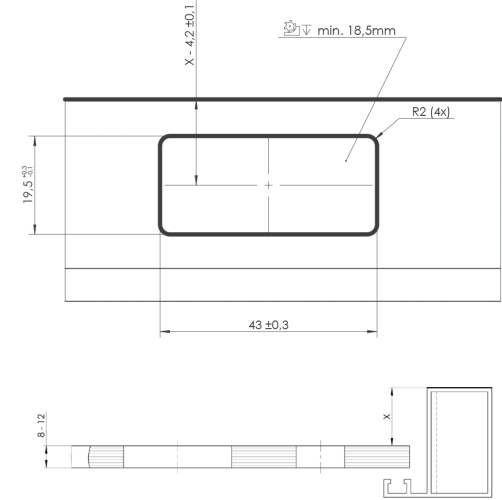

ALU2

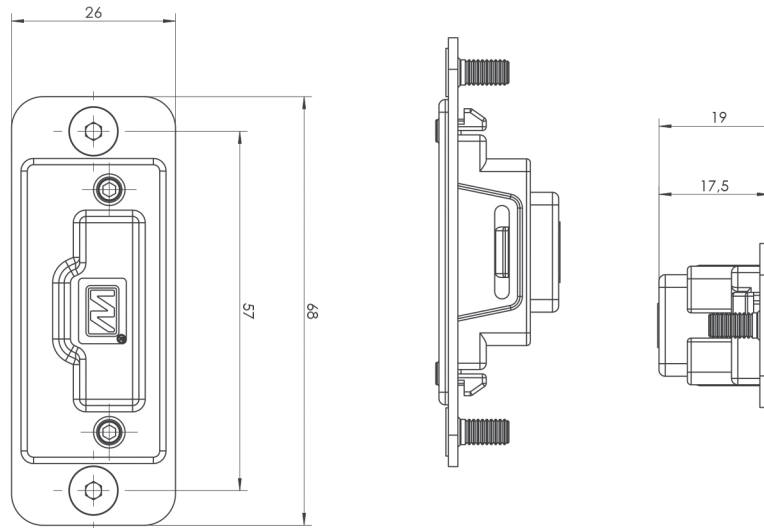

INSTALLATION IN THE FRAME PROFILE WITH A THICKNESS WALLS **OVER 2,5MM**. NECESSARY TO PERFORM ADDITIONAL M4 HOLES.

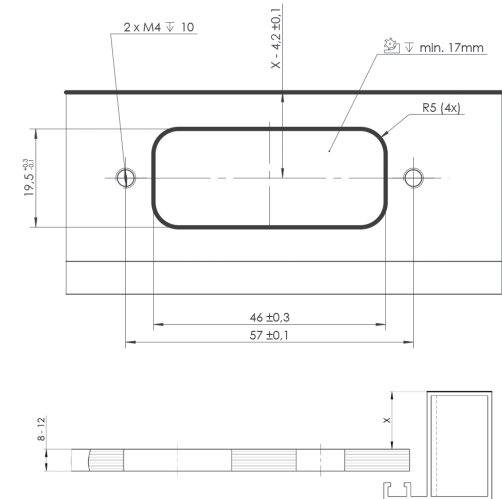



DOOR FRAME LOCK

LOCK / GLASS SHEET

WZAM SMIOZI
GLASS SHEET -
DOOR FRAME LOCK

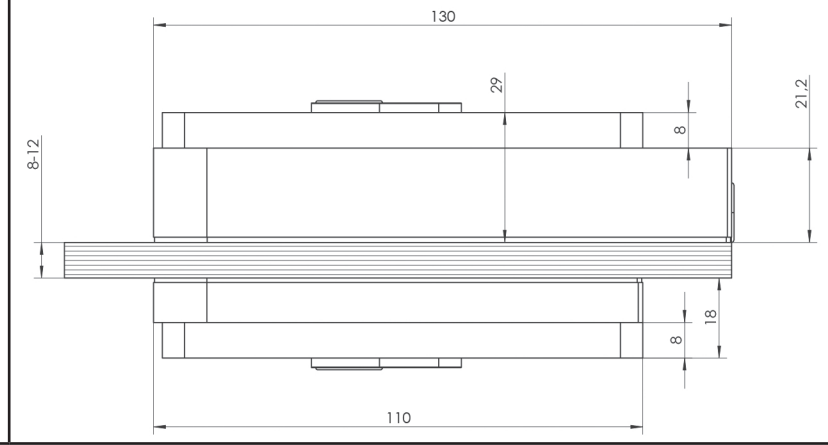

WZAM SMIOZ2
GLASS SHEET -
GLASS SHEET LOCK

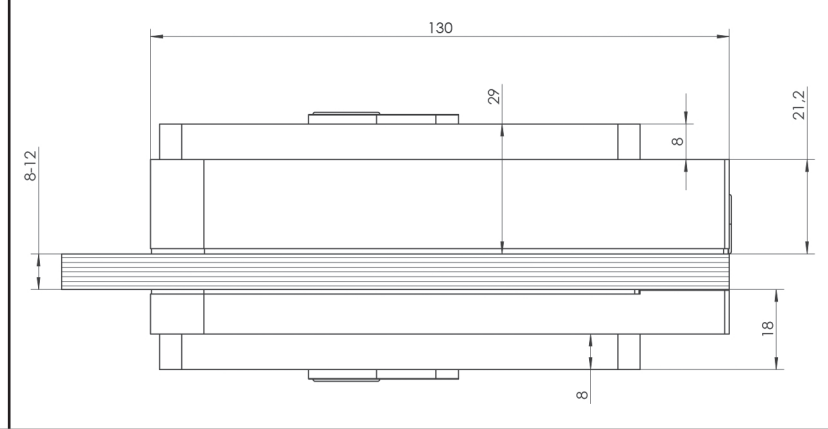

WZAM-P SMIOZ2
GLASS SHEET -
FLOOR LOCK

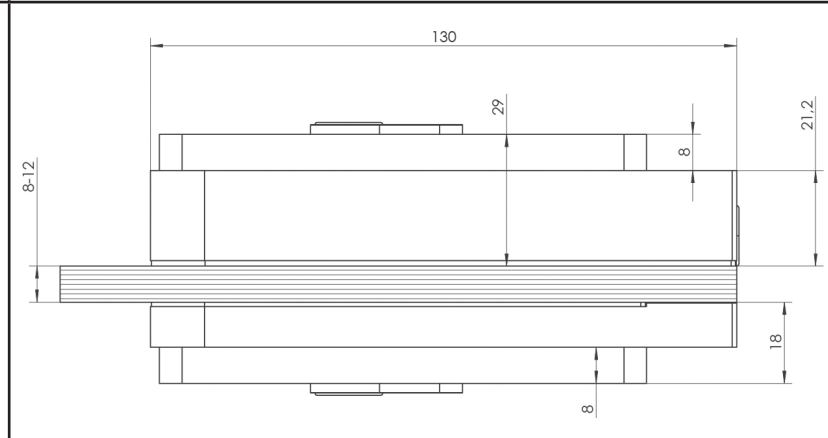

- 
7016
- 
7021
- 
7024
- 
9005
- 
8077
- 
8019
- 
8017
- 
8003
- 
9001
- 
1036W
- 
9010
- 
9016
- 
7035
- 
9006
- 
SILVER
- 
ANODE NATURAL
- 
INOX COATING
- 
GOLD W3
- 
GOLD W4
- 
RAL
- 
C-35 ANODE
BLACK F40



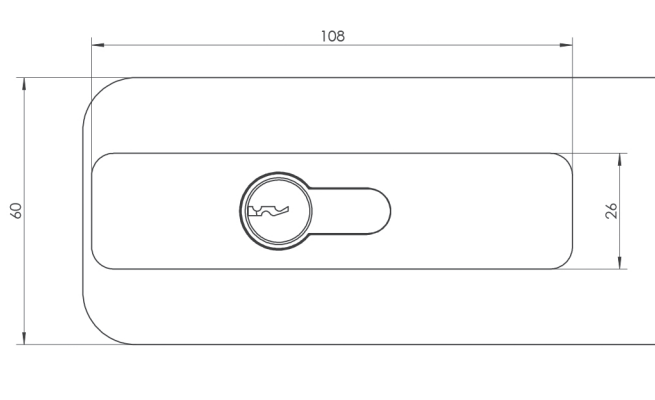

SINGLE-SIDED WZAM SM1OZ1

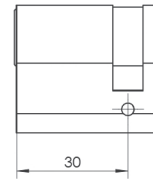

DOUBLE-SIDED WZAM SM1OZ1

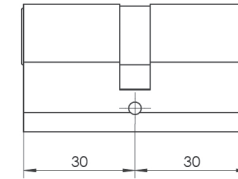

TOOLING IN GLASS SHEET

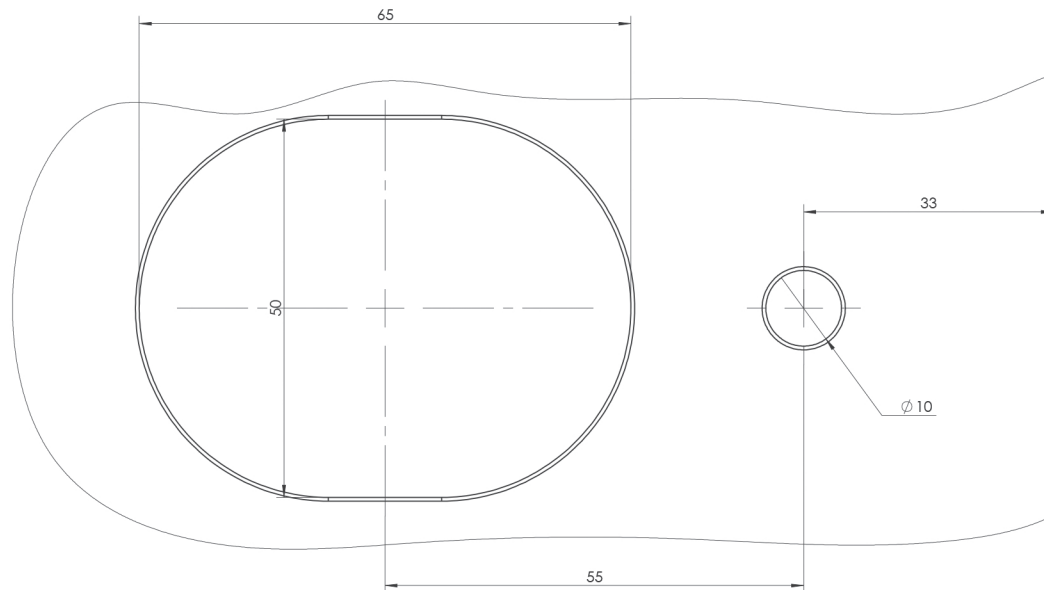

TOOLING FOR THE FLOOR CATCH



Almost all handles can also be easily installed on a glass sheet.

Specially developed fixings are required to ensure that the whole process runs smoothly.

Glass is a material that requires an appropriate approach in terms of processing and installation, which is why it is not possible to install some handles on it. Such exceptions to our range are the K and KA series handles, as well as the PS series handles. The other handles can be installed on the glass without any problems.

The handles which are made of high-quality 316 stainless steel and mounted on glass doors are ideal for industrial or swimming pool areas with increased humidity, as well as in office spaces.

Handles on glass doors not only fulfil their practical function, but also elegantly blend in with the appearance of the surroundings.





WALA Sp. z o.o.
ul. Parkowa 16
43-365 Wilkowice
tel. +48 33 82 72 390
wala@wala.pl
www.wala.pl