

INSTRUKCJA PRZYGOTOWANIA PROFILI POD MONTAŻ ZAWIASU ROLKOWEGO NA PRZEGUBIE WRP

INSTRUCTIONS FOR PREPARING PROFILES FOR
WRP ROLLER HINGE INSTALLATION
*ANLEITUNG ZUR PROFILVORBEREITUNG - MONTAGE
DES WRP ROLLENBANDES*

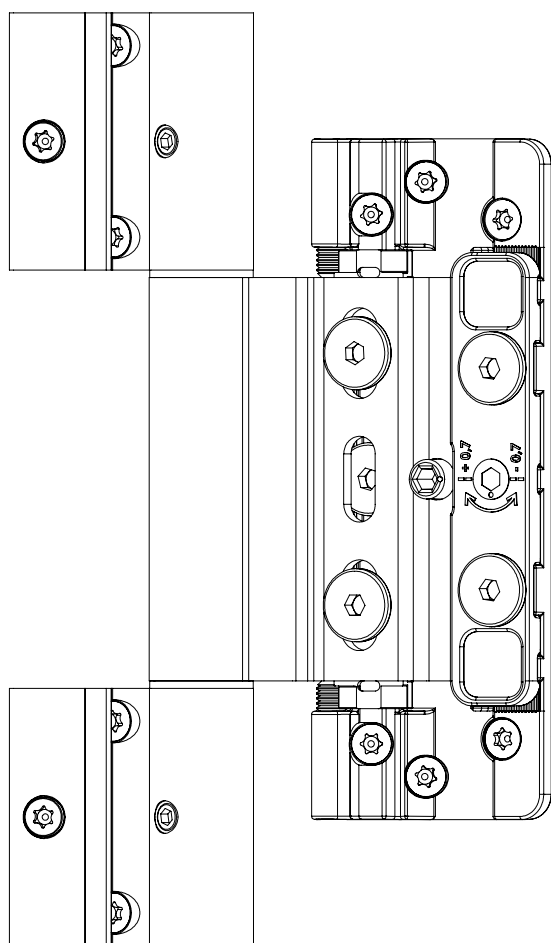

SKRZYDŁO DRZWI:
DOOR SASH:
TÜRBLATT:

①

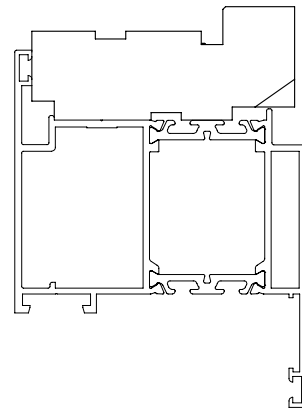
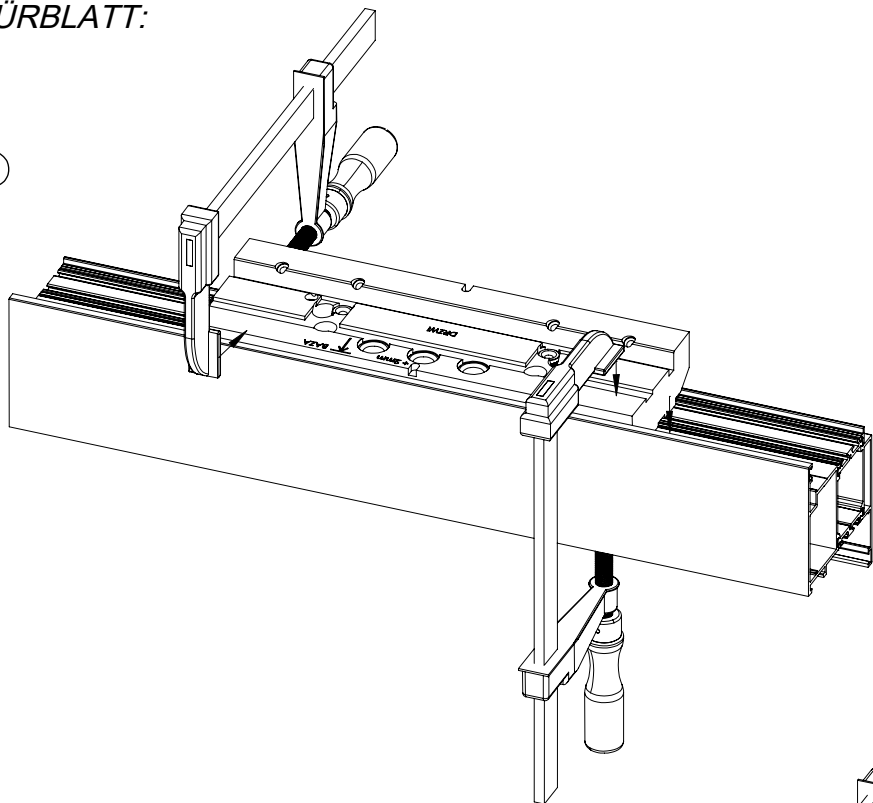

②

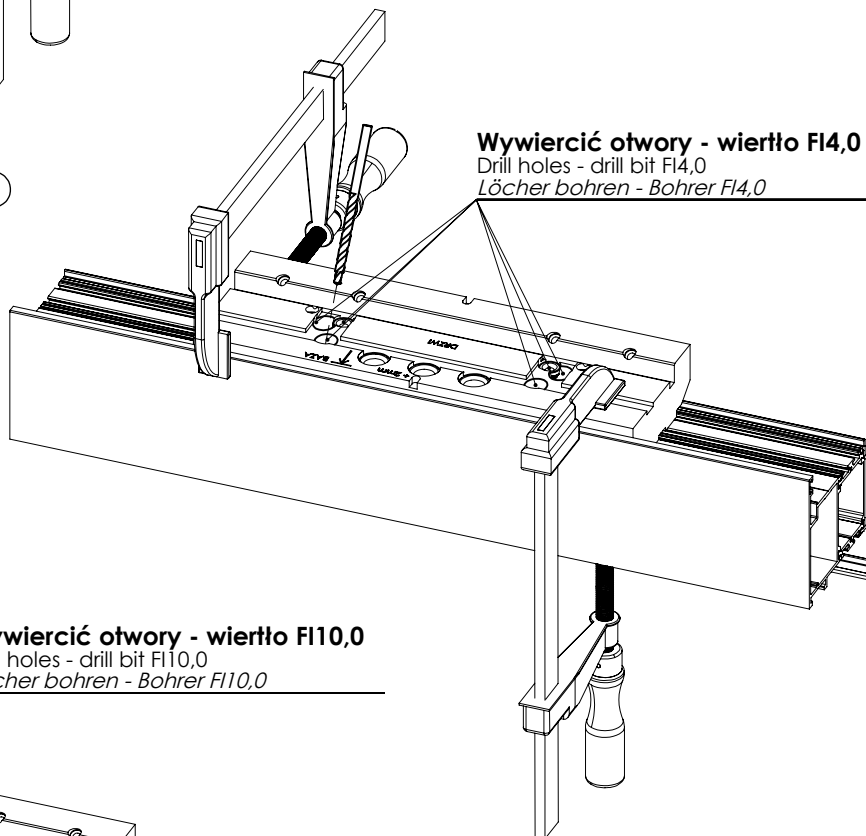

Wywiercić otwory - wiertło F14,0
Drill holes - drill bit F14,0
Löcher bohren - Bohrer F14,0

③

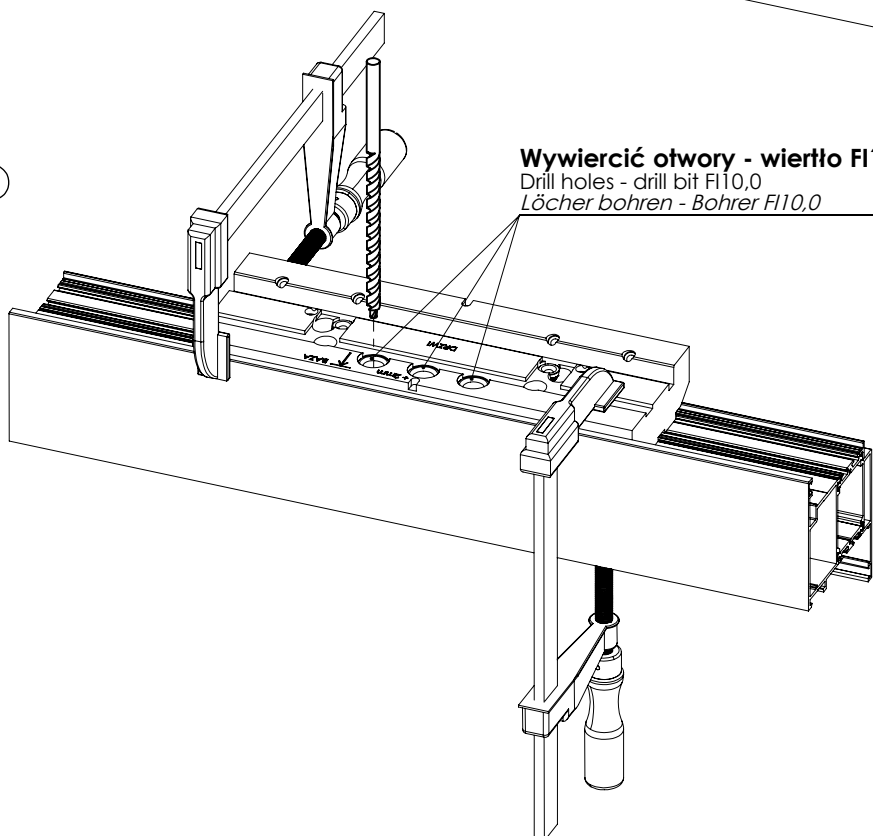

Wywiercić otwory - wiertło F110,0
Drill holes - drill bit F110,0
Löcher bohren - Bohrer F110,0

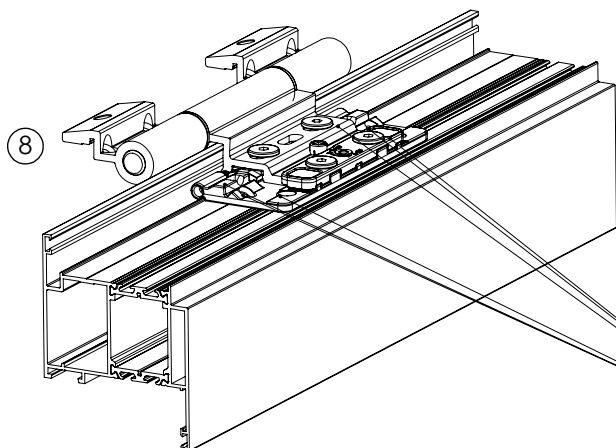
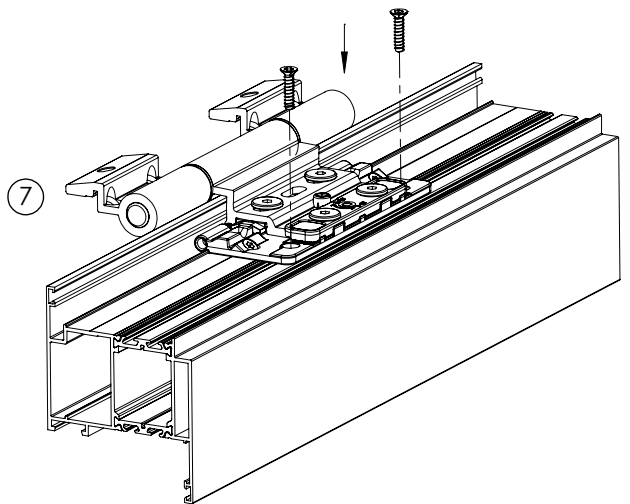
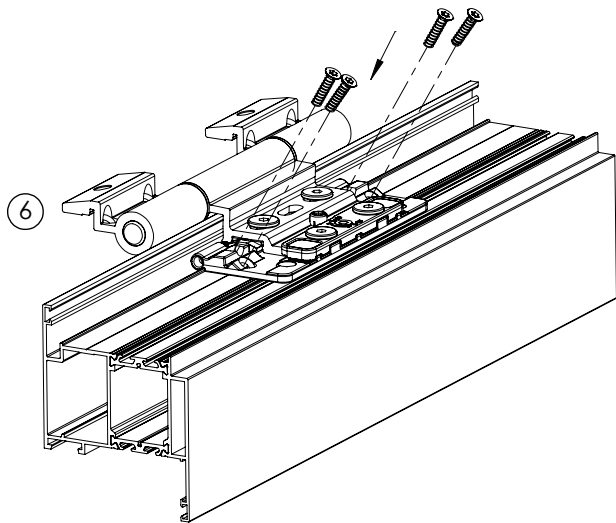
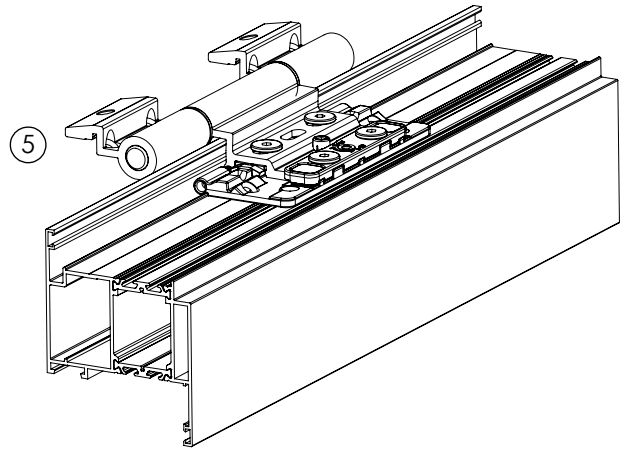
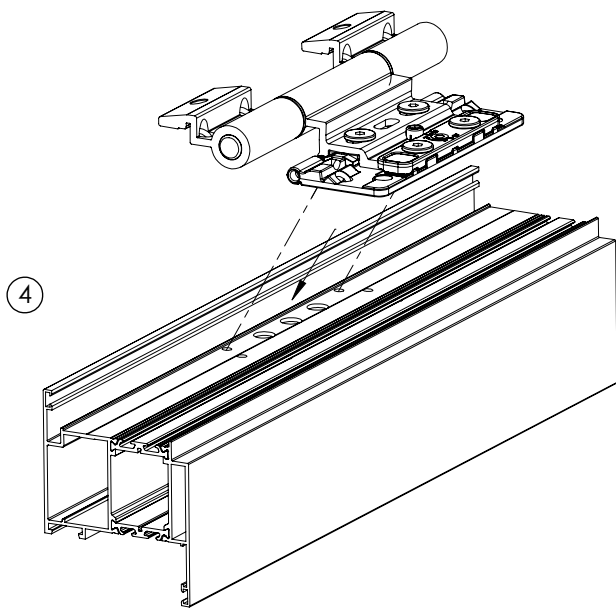

Dokrećić 4-5Nm - T25

Tighten with a tightening torque of 4-5Nm - T25
die Schrauben mit 4-5Nm festziehen - T25



OŚCIEŻNICA:
THE DOOR FRAME:
TÜRRAHMEN:

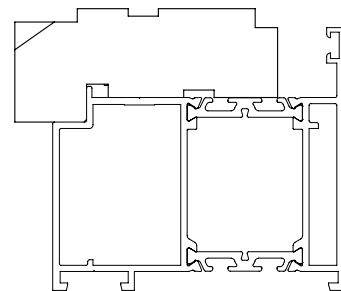

①

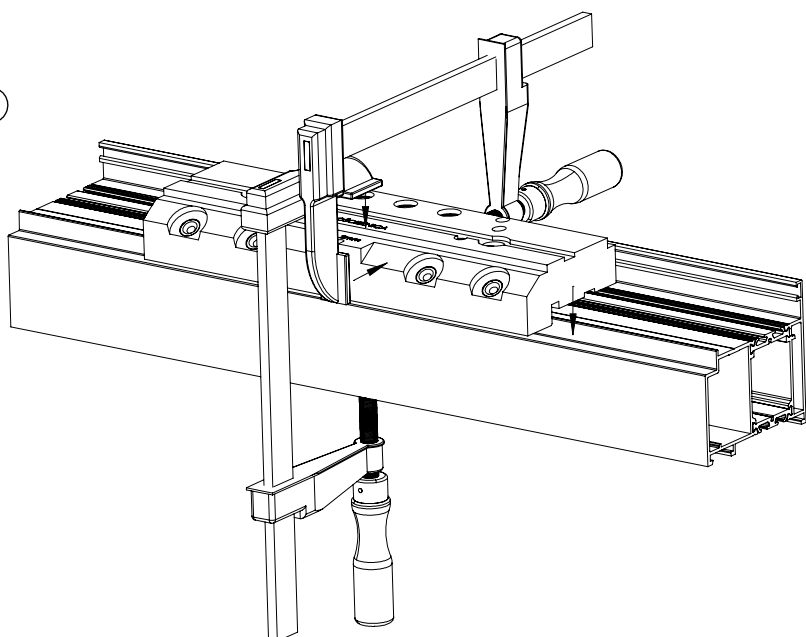

②

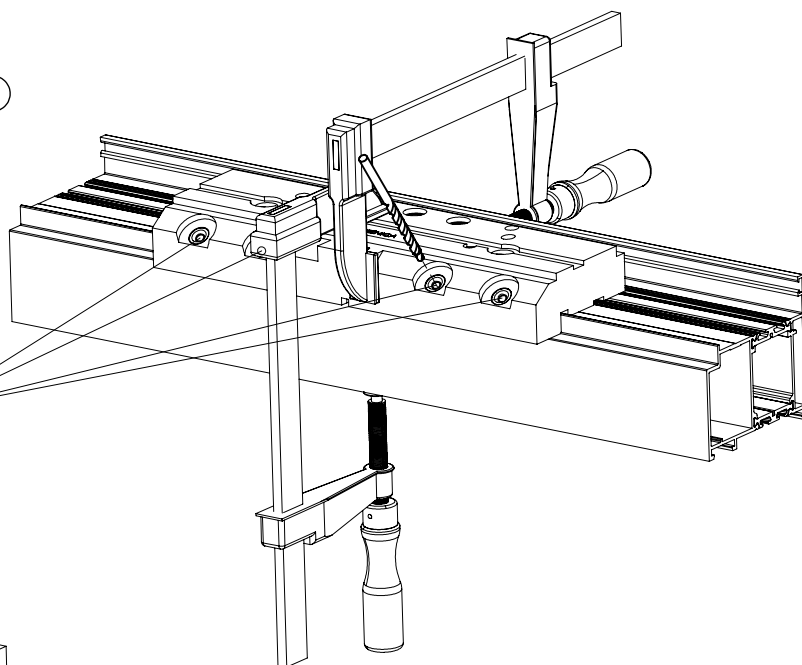

Wywiercić otwory - wiertło F14,0
Drill holes - drill bit F14,0
Löcher bohren - Bohrer F14,0

③

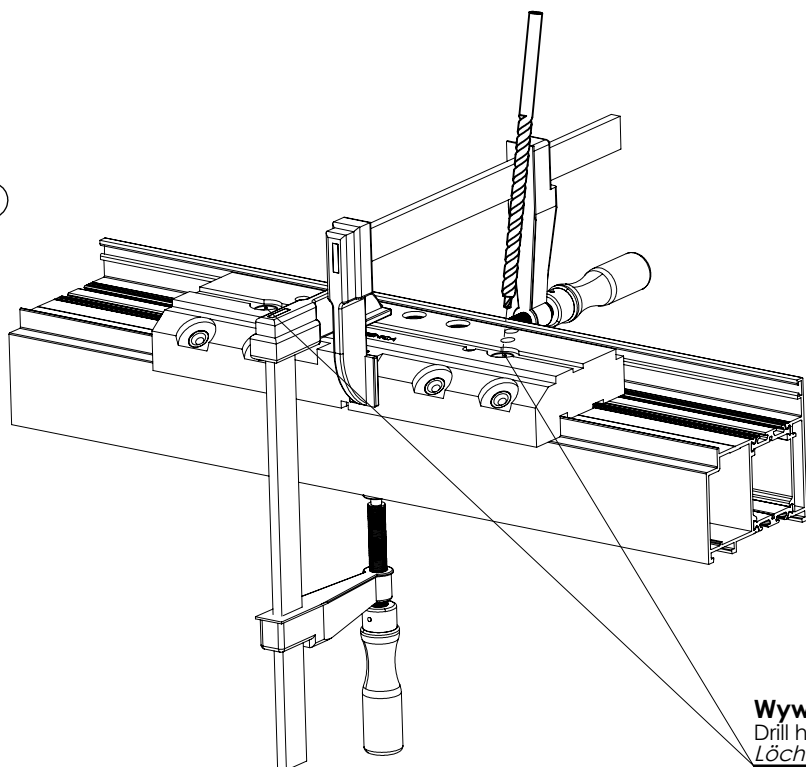

Wywiercić otwory - wiertło F15,0
Drill holes - drill bit F15,0
Löcher bohren - Bohrer F15,0



4

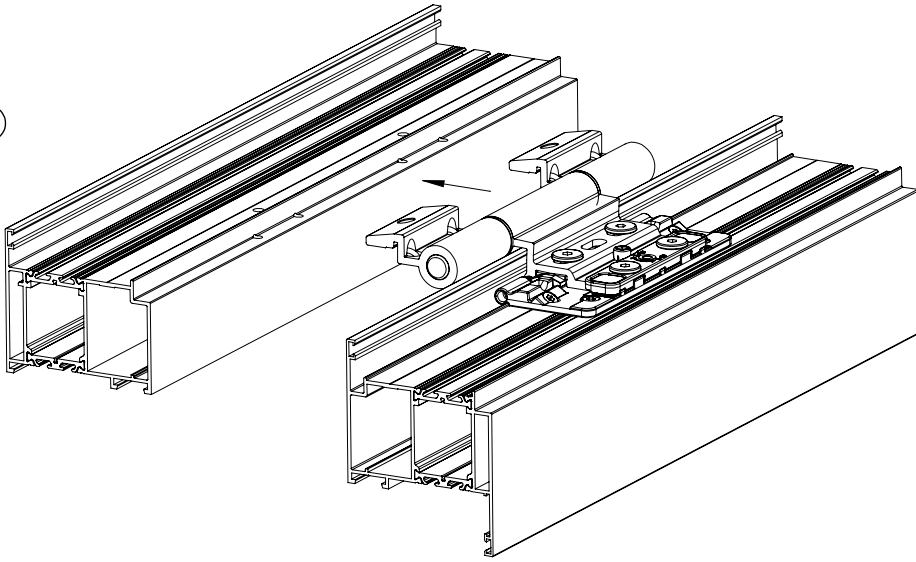

5

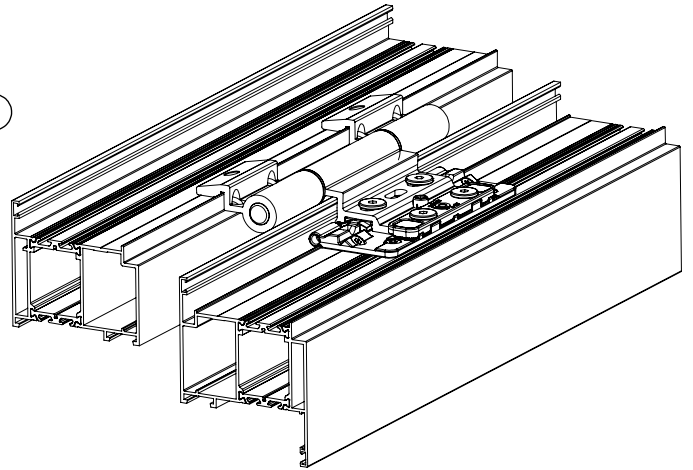

6

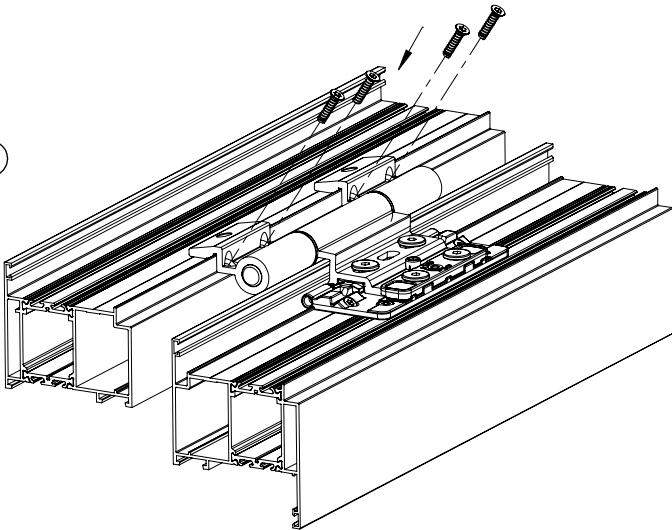

7

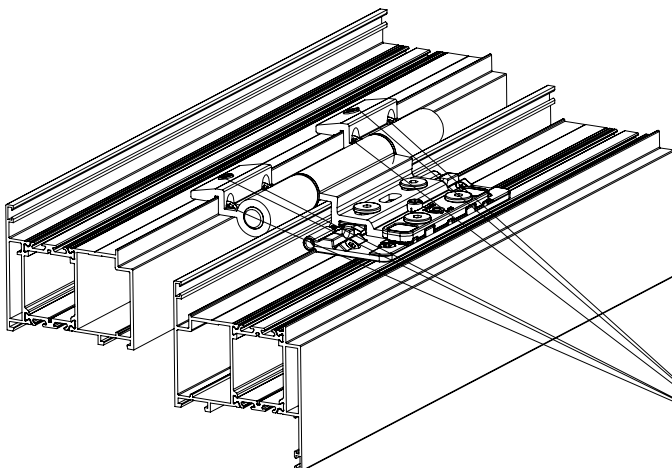
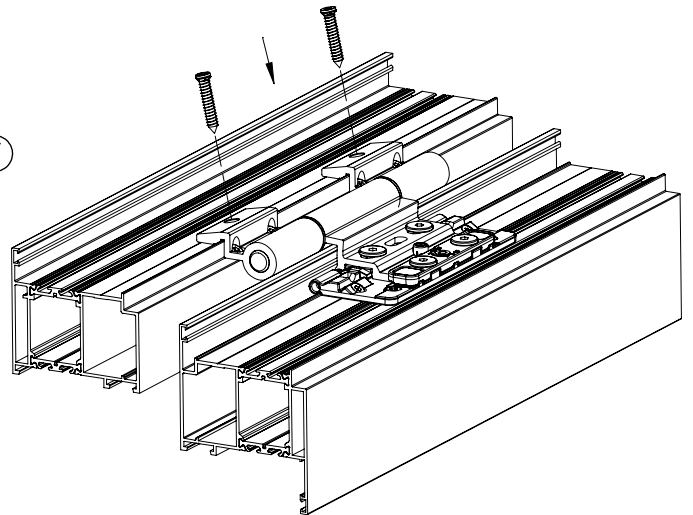

Dokrećić 4-5Nm - T25

Tighten with a tightening torque of 4-5Nm - T25
die Schrauben mit 4-5Nm festziehen - T25

